

GE Healthcare

ÄKTAdesign Pump P-920

User Manual



ÄKTA

Contents

1	Introduction	
1.1	General	7
1.2	Accessories	8
1.3	Safety	8
2	Installation	
2.1	Unpacking	10
2.2	General precautions	10
2.3	Connecting electrical signal cables	11
2.4	Connecting to UniNet-1 communication link	12
2.5	Connecting to supply voltage	12
2.6	Rinsing tubing	12
2.7	Connecting the inlet and outlet tubing	13
2.8	Running-in the new pump	13
2.9	Installation of accessories	14
3	Operation	
3.1	On/off	16
3.2	Menu selection and settings	16
3.3	Menu overview	17
3.4	Starting and stopping the pump	18
3.5	Setting the flow rate and starting the pump	19
3.6	Setting concentration B	20
3.7	Running a simple gradient	20
3.8	Ending the run and storage	21
3.9	Changing eluent	21
3.10	Restart after power failure	22
4	Maintenance	
4.1	Recycling	23
4.2	Periodic maintenance	24
4.3	Pump cleaning	24
4.4	General care	24
4.5	Changing rinsing solution	25
4.6	Testing leakage	25

4.7	Replacing the piston seal	27
4.8	Replacing a damaged piston	30
4.9	Cleaning the 6-port pump valve	30
5	Trouble-shooting	
5.1	General	31
5.2	Recycling	31
5.3	Faults and actions	31
5.4	Error messages	33
5.5	Checking the pump pressure	36
Appendix A Description		
A.1	Module	37
A.2	Rear panel	37
A.3	Fluid delivery	38
A.4	6-port pump valve	39
A.5	Pressure monitoring	39
A.6	Protective covers	39
A.7	Using an external chart recorder	40
Appendix B Menus		
B.1	Check menu	41
B.2	Setup menu	42
B.3	Alarm timer	44
B.4	Service displays	45
B.5	Menu and text overview	46
Appendix C Technical Specifications		
C.1	Operating data	47
C.2	Physical data	48
C.3	Regulatory Requirements	49
Appendix D Accessories and Consumables		
Appendix E Short Instructions		

About this manual

This manual comprises 3 parts; a practical part (sections 1–5), a reference part (sections A–D), and a quick guide (section E). Sections 1–5 contain the necessary information for installing, operating and maintaining the instrument.

Important user information

All users must read this entire manual to fully understand the safe use of Pump P-920.

Important!

Pump P-920 is intended for research use only, and should not be used in any clinical or in vitro procedures for diagnostic purposes.

Pump P-920 should not be used in any clinical or in vitro procedures for diagnostic purposes.

Safety notices

This manual contains warnings and cautions concerning the safe use of the product. See definitions below.



WARNING! The WARNING symbol and notice highlight instructions that must be followed to avoid personal injury. Do not proceed until all stated conditions are clearly understood and met.

CAUTION! The CAUTION notice highlights instructions that must be followed to avoid damage to the product or other equipment. Do not proceed until all stated conditions are met and clearly understood.

Notes

Note: A Note is used to indicate information that is important for trouble-free and optimal use of the product.

Recycling



This symbol indicates that the waste of electrical and electronic equipment must not be disposed as unsorted municipal waste and must be collected separately. Please contact an authorized representative of the manufacturer for information concerning the decommissioning of equipment.



WARNING! This is a Class A product. In a domestic environment, it might cause radio interference, in which case the user might be required to take appropriate measures.



WARNING! All repairs should be done by personnel authorized by GE Healthcare. Do not open any covers or replace parts unless specifically stated in the instructions.

CE-certification

This product complies with the European directives listed below, by fulfilling corresponding standards. A copy of the Declaration of Conformity is available on request.

- 73/23/EEC, Low Voltage Directive
- 89/336/EEC, EMC Directive

The CE logo and corresponding declaration of conformity, is valid for the instrument when it is:

- used as a stand-alone unit, or
- connected to other CE-marked GE Healthcare instruments, or
- connected to other products recommended or described in this manual, and
- used in the same state as it was delivered from GE Healthcare except for alterations described in this manual.

Note: The Declaration of conformity is valid only for systems that are marked with the CE logo:



1 Introduction

1.1 General

Pump P-920 is a high precision laboratory pump for use in liquid chromatography and other applications where constant flow is required. The performance of Pump P-920 is accurate and reproducible from low flow rates over the whole pressure range. The chemical resistance of the pump allows its use with corrosive liquids and organic solvents as well as aqueous solutions with high salt concentrations.

Pump P-920 facilitates routine chromatography work.

It is utilized as system pump in ÄKTAfplc™ chromatography systems, or is used as a stand-alone unit. The flow rate is set locally with a front dial, or from a PC running UNICORN™ 3.0 or higher.

Pump P-920 works with a wide range of columns and media supplied by GE Healthcare.

The pump can be used to form accurate and reproducible gradients.

In stand-alone configurations, setup parameters are stated in a Setup menu, see reference information in section B.2.

Pump P-920 features:

- A pressure sensor connected to pump module A and B.
- Pulse compensation:

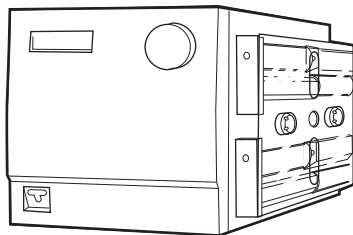

1.2 Accessories

Mixer M-925 can be connected to the pump. When P-920 is connected to UNICORN, the mixer can be controlled on/off/auto from UNICORN. When P-920 is run as a stand-alone unit, the mixer is operated via the local user interface.

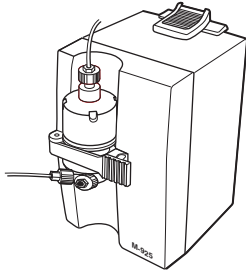

1.3 Safety

- The module is designed for indoor use only.
- Do not use in a dusty atmosphere or close to spraying water.
- Do not block the air inlet and outlet of the unit.



WARNING! The module must be connected to a grounded mains socket.



WARNING! Always disconnect the power supply before attempting to replace any item on the module.



WARNING! The module must not be opened by the user. It contains high voltage circuits that can give a lethal electric shock.



WARNING! When using hazardous chemicals, all suitable protective measures, such as protective glasses, must be taken.



WARNING! NaOH is injurious to health. Avoid spillage.



WARNING! Incorrectly fitted tubing may loosen, causing a jet of liquid to spray out. This is especially dangerous if hazardous chemicals are being used. Connect the tubing by first inserting the tubing fully, then tightening the connector fingertight.



WARNING! During normal operation, all protective covers over internal capillaries, piston rods and glass cylinders must be in place when running the pump.



WARNING! Hands and fingers risk being squeezed between the piston driving arm and the pump housing when running the pump without the protective covers fitted.



WARNING! The power switch shall always be easily accessible so that the unit can easily be disconnected in the event of an emergency.



WARNING! Only GE Healthcare approved products may be connected to the power outlets on the back of P-920. The maximum permissible load 500 VA. The leakage current may not exceed 3.5 mA.

2 Installation

2.1 Unpacking

Unpack the module and check the items against the supplied packing list. Inspect the items for obvious damage that may have occurred during transportation.

We recommend that all packing materials be retained if onward transport of the module is expected.

CAUTION! Read the following information carefully to ensure that the module is installed correctly.

2.2 General precautions

The module should be installed in a non-corrosive atmosphere.

The module should be located in a place of low temperature variations, away from heat sources, draughts and direct sunlight. Ventilation openings should not be blocked.

The module may be operated at normal ambient temperatures in the range +4°C to +40°C.

The module should be installed on a stable laboratory bench or in an ÄKTA™ design chromatography system. To ensure correct ventilation, a free space of 0.1 m is required behind and in front of the module. Place the module directly on the bench. To ensure that the ventilation inlet below the front is not blocked, do not place soft material under the module.

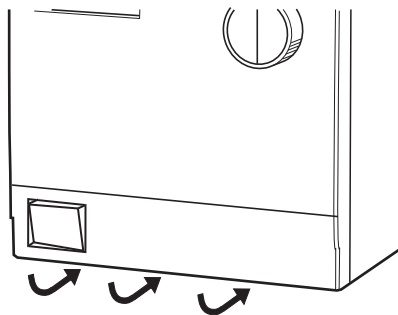

2.3 Connecting electrical signal cables

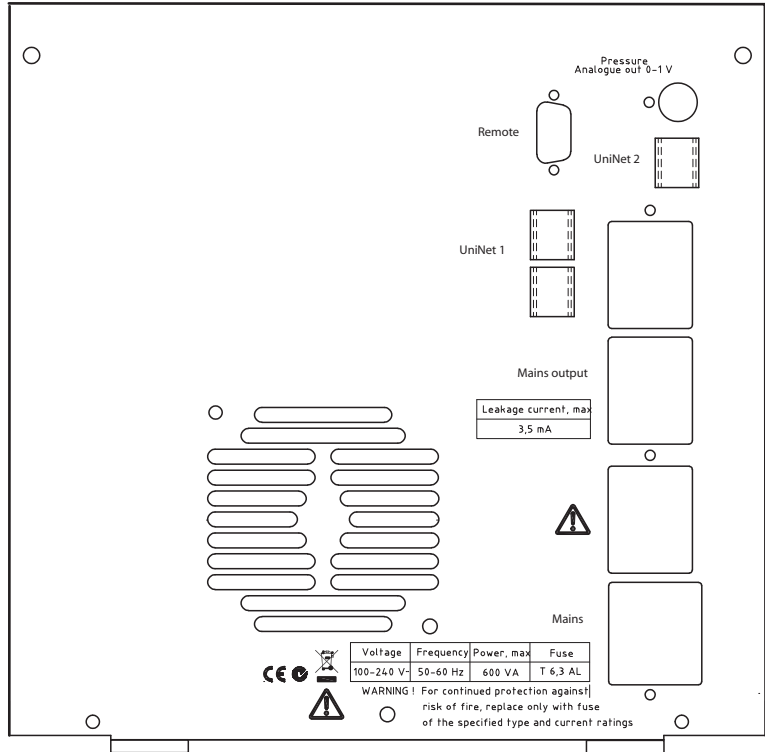

The sockets for electrical signals are located on the rear panel.

Connecting to chart recorder (if used)

- 1 Connect the chart recorder to the Mini-DIN-socket Pressure Analogue out 0-1 V using the cable supplied.

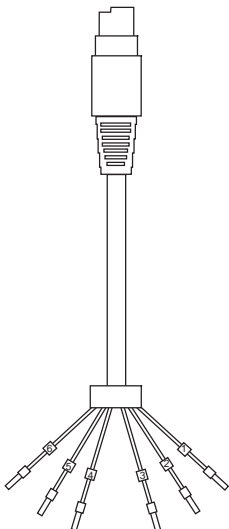

Pin	Signal
1	Pressure signal
2	Signal ground
3-6	Not used (reserved for factory testing)

Note: The signal cable is delivered with protective covers on each wire. Do not remove the protective covers from unused connections as a short circuit may disturb the measurement.

- 2 Set the recorder to 0 to 0.5 V input, full scale. 0.1 V corresponds to 1 MPa.

2 Installation

2.4 Connecting to UniNet-1 communication link

2.4 Connecting to UniNet-1 communication link

When used in ÄKTAdesign chromatography system, the pump is controlled from a PC running UNICORN version 3.0 or higher via UniNet-1 cables.

CAUTION! The mains power to the ÄKTAdesign chromatography system must be switched OFF before connecting the module to the UniNet-1 link.

- 1 Connect two UniNet-1 cables to the UniNet-1 connectors.
 - The module can be connected in series anywhere in the chain between the PC and the termination plug.
 - The UniNet-1 link connects, in series, the PC with Pump P-920 and other modules.
 - The termination plug is connected to the last module in the chain.

2.5 Connecting to supply voltage

- 1 Make sure the on/off switch is in the OFF-position marked O.
- 2 Connect a mains cable between the module and a grounded mains socket. Any voltage from 100 to 240 V AC, 50 to 60 Hz can be used.



WARNING! The module must be connected to a grounded mains socket.

The module contains one user-replaceable fuse. See Technical Specifications for fuse ratings.

2.6 Rinsing tubing

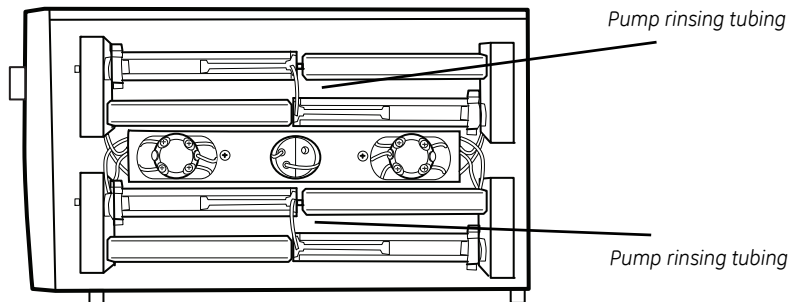

The rinsing tubing for the piston seals is installed at the factory and filled with 20% ethanol. Check that the rinsing solution is present behind the pistons and that the rinsing tubing is connected and undamaged. Always use 20% ethanol as rinsing solution. Change rinsing solution at least every month.

2.7 Connecting the inlet and outlet tubing

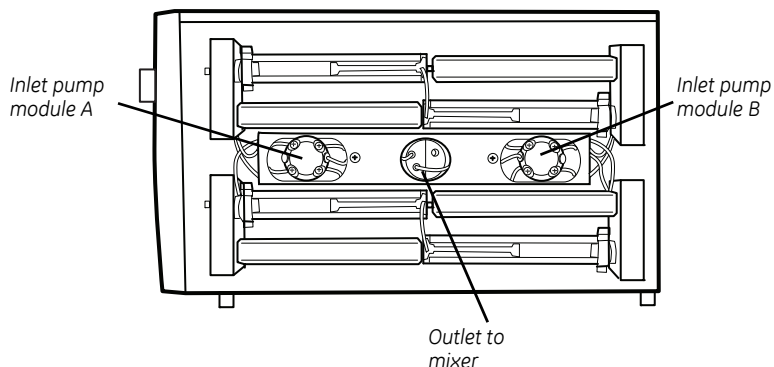

In ÄKTAfplc, the inlet and outlet tubing are installed at the factory.

When using P-920 in stand-alone applications, the inlet and outlet tubing must be installed.

The outlet tubing (PEEK tubing, i.d. 0.50 mm, o.d. 1/16") has tubing connectors attached at both ends.

The inlet tubings (A1, B1, teflon tubing i.d. 1.6 mm, o.d. 1/8") have tubing connectors attached at one end and inlet filters at the other end. The inlet filters have replaceable filter inserts.

The inlet tubings are connected to the inlets marked **A IN** and **B IN** on the pump valves and the outlet tubing is connected to the upper connection on the pressure sensor marked OUT. The other end of the outlet tubing is connected to a mixer inlet.

2.8 Running-in the new pump

General

To be able to follow this section, you must know how to operate the pump. Read through section 3 Operation before continuing.

Note: *Running with air is not harmful to the pump sealings. However, the sealing ring lifetime might be shortened if the pump pumps air for long periods.*

The pump is tested at the factory prior to delivery and washed with 20% ethanol. Remains of this is removed by running-in the pump with a liquid such as distilled water that is miscible with ethanol. After running-in, the pump is primed for the chromatographic run.

2 Installation

2.9 Installation of accessories

Running-in

- 1 Submerge the inlet tubings in a suitable reservoir filled with degassed distilled water. Place the outlet in a waste container.
- 2 Switch the mains power switch on the front panel to ON. A selftest is carried out.

Selftest
Please wait...

Note: *When the pump is run for the first time after replacing a sealing, friction between the glass cylinder and the dry sealing may give rise to some noise. This will disappear when the sealing has been wetted.*

- 3 Leakage is tested by checking the pump pressure against a blocked outlet using distilled water and a 5/16" stop plug. The test is carried out from the pump dial and display. A chart recorder connected to the analogue pressure output can be useful to record the pressure reading during this test. See section 4.6 Testing leakage for details.
- 4 Remove the stop plug and reconnect the outlet tubing. The pump is then ready for operation. Before changing solvent, see section 3.9 Changing eluent.

2.9 Installation of accessories

Install Mixer M-925 as follows

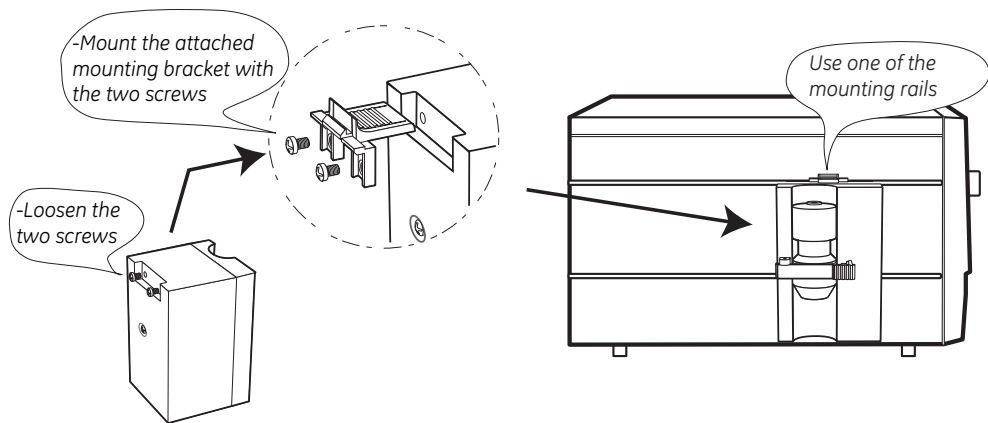

CAUTION! Before connecting the mixer M-925, make sure the power switch is in OFF position.

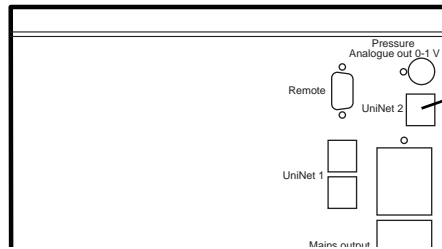

The mixer is connected to the UniNet 2 connector

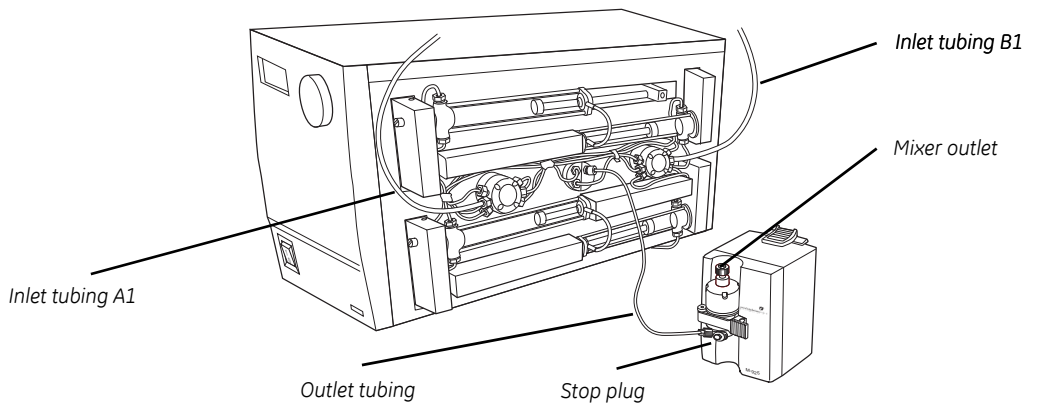

3 Operation

3.1 On/off

Selftest
Please wait...

Pump P-920
<versionno.>

End 0.00ml/min
0.00MPa 0.0%B

Switch on the module at the mains switch on the front panel. At switch on, the module performs a selftest. Several beeps are heard during this process. If an error is detected, an error message is shown.

Name and software version number is shown for 2 seconds.

The selftest takes approximately 1/2 minute. When start-up is completed with no errors, the display shows the main menu with the pump in End mode. All parameters are factory set to default values.

3.2 Menu selection and settings

Menu selection

A specific menu is selected by turning the front selection dial clockwise or counter-clockwise. When the required menu is visible, the menu or selection is accepted by pressing the **OK**-button.

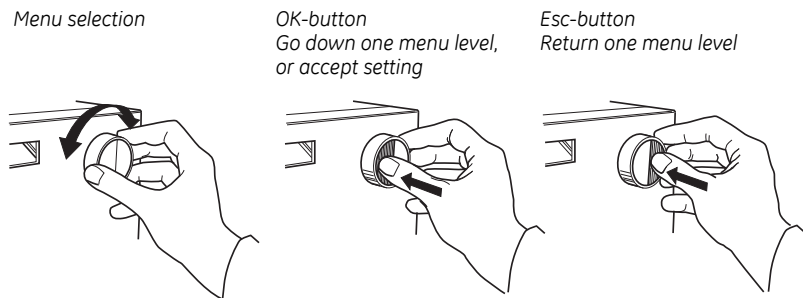

If a menu has sub levels, the sub menu is displayed by pressing **OK**. Pressing **ESC** moves back one menu level.

Return to higher menu levels

Pressing **ESC** repeatedly returns to the main operating menu. Turn the dial one click counter-clockwise to return to the work mode changing menu.

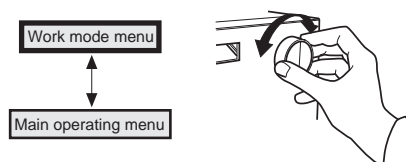

Selecting a value

A cursor below a text or numerical value shows what is affected by the dial. To increase the value, turn the dial clockwise. To decrease the value, turn the dial counter-clockwise. The value can be reset by turning the dial several clicks counter-clockwise.

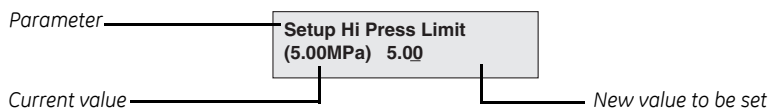

To simplify entering large numerical values, the cursor moves up to the next digit if the dial is turned quickly in one direction. The cursor moves back one place to the right every two seconds if the dial is not turned. The text or numerical value displayed is accepted by pressing OK. To cancel, press ESC.

3.3 Menu overview

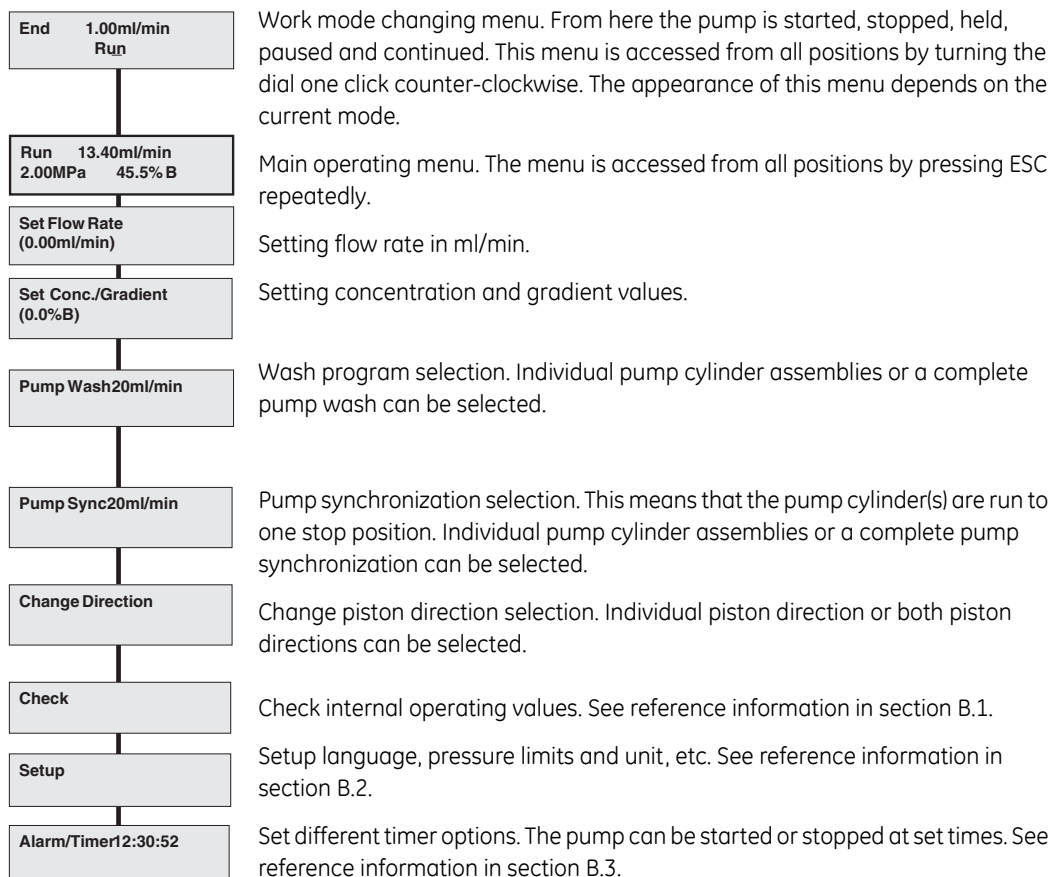

3 Operation

3.4 Starting and stopping the pump

3.4 Starting and stopping the pump



WARNING! Incorrectly fitted tubing may loosen, causing a jet of liquid to spray out. This is especially dangerous if hazardous chemicals are being used. Connect the tubing by first inserting the tubing fully, then tightening the connector fingertight.



WARNING! All protective covers over internal capillaries, piston rods and glass cylinders must be in place when running the pump.

Run	13.40ml/min
2.00MPa	45.5% B

Main operating menu

The main operating menu shows the current flow rate together with work mode indication, pressure and %B, if used. The available work modes are:

- Run** The pump is running with set flow rate.
- End** The pump is not running. Flow rate and gradient are reset.
- Pause** The pump is stopped but the set flow rate and the gradient are retained.
- Hold** The gradient is held at the value displayed and the pump continues to run.
- Continue** Not a work mode. Used to continue from **Hold** or **Pause**.

Work mode changing menu

Run	1.00ml/min
End Hold Pause	

Current work mode

Available actions for the current work mode

Work mode changes are made in the work mode changing menu above the main operating menu (turn dial counter-clockwise). The current work mode is shown in the upper left corner of the display. Available actions are shown at the lower right. There are four different displays for this menu and the menu displayed will depend on the current mode (see below). When a new mode is selected, the appearance of the menu will change.

Pressing **OK** in a work mode changing display selects the underlined work mode. Different work modes are selected by turning the dial.

End	1.00ml/min <u>Run</u>	Pause	1.00ml/min End <u>Hold</u> Continue	Hold	1.00ml/min End Continue <u>Pause</u>
-----	--------------------------	-------	--	------	---

- To start the pump, select Run and press **OK**.
- To stop the pump, select End and press **OK**.

Preparation before starting

CAUTION! Before the start of each run, always ensure that there is an adequate supply of eluent in the reservoirs. Do not allow the pump to run dry, since this will affect the lifetime of the sealings.

- 1 Check that there is sufficient solvent present for the run, and that the solvent filter is fully immersed. If the eluent is to be changed, see section 3.9 Changing eluent.

Note: *The pump may not work if the buffer vessels are sealed, or if they are placed too far below the pump inlets. Do not close the vessels off completely. Place the buffer vessels on the workbench or on the buffer tray on top of ÄKTAfplc.*

- 2 Check that there is rinsing liquid (20% ethanol) in the rinsing system (behind the piston heads).
- 3 Set the pressure limit. Refer to section B.2.1 for reference information. If the pressure limit is exceeded, the pump is stopped.

Emergency stop

Use the front power switch, or disconnect the mains supply from the pump.

3.5 Setting the flow rate and starting the pump

Set Flow Rate
(0.00ml/min) 2.50

- 1 Select operating menu Set Flow Rate and press **OK**.
- 2 Set the desired value and press **OK**.
- 3 Go to the work mode menu, select **Run** and press **OK**.
- 4 To change the flow rate while the pump is running, repeat steps 1 and 2.
- 5 To stop the pump, go to the work mode menu, select **End** and press **OK**.

In UNICORN, select instruction **Flow** in **System Control:Manual:Pump**. Click on **Execute** and the pump will start.

3 Operation

3.6 Setting concentration B

3.6 Setting concentration B

A percentage of eluent B can be set.

Set Conc./Gradient
(0.0%B)

- 1 Select operating menu Set Conc./Gradient and press **OK**.
- 2 When the display shows Set Concentration B, press **OK**.
- 3 Set the desired %B value and press **OK**.

Set Concentration B
(0.0%B) 5.0

In UNICORN, select instruction **Gradient** in **System Control:Manual:Pump**. Set the desired %B value.

3.7 Running a simple gradient

Gradients can be run in time or volume base. The default is time base. To change base, see section B.2.4 for reference information.

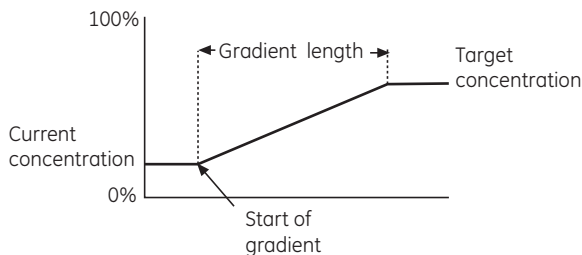

The gradient is run from current concentration to target concentration, over a set time or volume. The gradient can be set in any operating mode.

Set Conc./Gradient
(0.0%B)

- 1 Select operating menu Set Conc./Gradient and press **OK**.

Set Gradient Length
(0.0min) 8.0

- 2 When the display shows Set Concentration B, turn the dial to select operating menu Set Gradient Length and press **OK**.

- 3 Set the desired value and press **OK**.

Set Gradient Target
(0.0%B) 50.0

- 4 Turn the dial to select operating menu Set Gradient Target and press **OK**. Set the desired gradient target value in %B and press **OK**. If the pump is in work mode **Run**, the gradient starts immediately.

- 5 At the end of the set gradient time, the pump continues to run at the target concentration.

In UNICORN, select instruction **Gradient** in **System Control:Manual:Pump**. In the **Parameters** window set **Target** and **Length**. Click on **Execute**.

3.8 Ending the run and storage

Overnight storage

The pump can be left filled with a buffer.

Note: *If buffers or water are stored at room temperature, bacterial growth may occur.*

If no further runs are planned, the pump should be washed immediately with pure eluent. If aqueous buffers have been used, washing with pure distilled water is particularly important to prevent salt precipitation.

Weekend and long term storage

Wash the pump with water and then fill it with 20% ethanol.

Pump wash operation

Pump Wash 20 ml/min

Pump Wash 20 ml/min
A B B&A

Washing
Please wait....

- 1 Immerse the inlet filters in a wash solution. Select operating menu Pump Wash and press **OK**.
- 2 When the display shows **Pump Wash A, B** and **B&A**, select **B&A** and press **OK**.
- 3 First pump B and then pump A is washed in sequence. The pump wash is performed with 20 ml/min for seven strokes each.

In UNICORN, select instruction **PumpWash** in **System Control:Manual:Pump**. In the **Parameters** window set **PumpA** and **PumpB**. Click on **Execute**.

3.9 Changing eluent

CAUTION! To prevent precipitation of crystals when changing from a salt-containing buffer to organic solvent, always wash the system with water as the intermediate liquid.

Note: *When changing from one eluent to another, it is extremely important that the two eluents are totally miscible with one another. If the two eluents are immiscible, the pump should be washed first with an intermediate liquid that is miscible with both eluents. Failure to do this will disrupt the flow from the pump.*

When changing from a salt-containing buffer to an organic solvent, use water as the intermediate liquid to prevent precipitation.

3 Operation

3.10 Restart after power failure

- 1 Stop the pump by setting it in **Pause** mode.
- 2 If not carried out from UNICORN, use a bypass tubing to replace the column.
- 3 Transfer the inlet tubing into the new eluent or into the intermediate liquid.
- 4 Perform a pump wash.
- 5 If an intermediate liquid is being used, transfer the inlet tubing into the final eluent and repeat step 4 with the new eluent.

In UNICORN, select instruction **PumpWash** in **System Control:Manual:Pump**. In the **Parameters** window set **PumpA** and **PumpB**. Click on **Execute**.

Note: *When high buffer purity is important, use an intermediate step. This avoids remains of the previous buffer in the inlet filter diffusing out in the new buffer.*

3.10 Restart after power failure

If the power supply to the pump is interrupted, it automatically restarts after performing a selftest when power is restored. All values under the **Setup** menu are retained. Other operating values, for example flow rate, are reset.

4 Maintenance

Note: *The piston seals have a limited lifetime depending on the flow rate, pressure and eluents used. The seals are regarded as consumables and are available as a sealing kit. The wear of the piston seals is not covered by the warranty of the pump. A typical lifetime is around 1000 run hours.*



WARNING! Always disconnect the power supply before attempting to replace any item on the module during maintenance.



WARNING! Incorrectly fitted tubing may loosen, causing a jet of liquid to spray out. This is especially dangerous if hazardous chemicals are being used. Connect the tubing by first inserting the tubing fully, then tightening the connector fingertight.

CAUTION! Only spare parts approved or supplied by GE Healthcare may be used for maintaining and servicing the module.

4.1 Recycling



This symbol indicates that the waste of electrical and electronic equipment must not be disposed as unsorted municipal waste and must be collected separately. Please contact an authorized representative of the manufacturer for information concerning the decommissioning of equipment.

Follow local rules and regulations when disposing of waste substances.

4.2 Periodic maintenance

Interval	Action (see procedures below)
Daily	General care
Monthly	Change rinsing solution (20% ethanol)
Every two months	Leakage test
When required	Fixing leaking connections Replacing the piston seals Replacing a damaged piston Cleaning or replacing 6-port pump valve

4.3 Pump cleaning

Perform a pump wash using a cleaning or sanitizing agent. The standard recommendation is to use 1 M NaOH and then wash out with buffer or distilled water.



WARNING! NaOH is injurious to health. Avoid spillage.

4.4 General care

Inspect the pump daily for eluent leaks.

Change direction
A B A&B

If, at any time, air bubbles are trapped in a cylinder assembly, purge the pump by manually changing the direction of the piston when the piston reaches its end position. Change direction several times until the air bubbles are removed.

General recommendations for all eluents

It is essential that all liquids passing through the pump are clean, pure and degassed. Impure or dirty eluents will not only cause baseline noise and drift, but also block the channels in the 6-port pump valves, shortening their lifetime. Degassing prevents formation of air bubbles, which can cause baseline noise, drift and deteriorating gradient formation.

Additional recommendations for aqueous eluents

After running with an aqueous eluent, the pump should always be thoroughly washed with pure, distilled water to prevent salt precipitation.

4.5 Changing rinsing solution

The rinsing solution should be changed monthly. Use a 20% solution of ethanol/distilled water.

- 1 Remove the rinsing tubing between the glass cylinders for both the A and B pump.
- 2 Select 50%B and run the pump at 20 ml/min to flush out the used rinsing solution. Allow the pump to perform a couple of strokes to remove as much rinsing solution as possible from the glass cylinders.
- 3 Stop the pump when the pistons are at the middle of the glass cylinders.
- 4 Refit the rinsing tubing to the lower cylinders in each pump module.
- 5 Add fresh rinsing solution to the lower cylinders by submerging the rinsing tubing open ends in rinsing solution and starting the pump. Continue to run until approximately half of the cylinder chambers are filled. Stop the pump.
- 6 Refit the rinsing tubing to the upper cylinders.
- 7 Run the pump and allow a couple of strokes to wash out as much contamination from the old rinsing solution as possible.
- 8 If required, repeat steps 1 to 6 one or two times, to ensure that all contamination is washed out.

4.6 Testing leakage

When using the Pump P-920 regularly, a leakage test should be performed every second month. When the pump is used intermittently, a leakage test should be performed before every use. After disassembly due to cleaning or repair, a leakage test should also be performed before use.

Leakage is tested by checking the pump pressure against a blocked outlet using distilled water and a 1/16" stop plug. The test is carried out from the pump dial and display. A chart recorder connected to the analogue pressure output can be useful to record the pressure reading during the test.

- 1 Set the pump to 0%B and select a flow of 20 ml/min.
- 2 Set the high pressure limit to 4.5 MPa and press OK.
- 3 Run the A pump until the piston which is delivering flow is at the middle of the glass cylinder. Stop the pump.
- 4 Plug the pump outlet at the pressure manifold using a 1/16" stop plug (18-1112-52).
- 5 Select a flow of 0.2 ml/min.

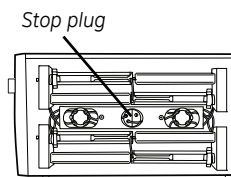

4 Maintenance

4.6 Testing leakage

- 6 Start the pump and let it run until the pressure limit is reached and the pump stops.
- 7 Check the pressure reading for two minutes. The pressure must not decrease more than 0.45 MPa during this time. If the decrease is larger, see Chapter 5 Trouble-shooting for actions.
- 8 Release the pressure from the pressure manifold by loosening the stop plug. Select a flow of 20 ml/min and run the A pump until the other piston, which is now delivering flow, is at the middle of the glass cylinder. Stop the pump.
- 9 Repeat steps 4 to 7.
- 10 Set the pump to 100%B and select a flow of 20 ml/min.
- 11 Release the pressure from the pressure manifold by loosening the stop plug. Run the B pump until the piston which is delivering flow is at the middle of the glass cylinder. Stop the pump.
- 12 Repeat steps 4 to 7.
- 13 Repeat steps 8 for the B pump.
- 14 Repeat steps 4 to 7.
- 15 Remove the stop plug and reconnect the outlet tubing to the pressure manifold.
- 16 Store the pressure recordings in the system logbook.

4.7 Replacing the piston seal

If there are signs of leakage between piston seal and glass cylinder, replace the piston seal of the leaking pump cylinder.

A seal leakage will gradually fill up the rinsing chamber completely, causing excess fluid to leak out around the rinsing tubing connections.

CAUTION! Do not disassemble the pump mechanism unless there is good reason to believe that the seal is leaking. Always ensure that sufficient spare components are available before attempting to replace the piston seal. We do not recommend refitting a used piston seal after removal.

Note: *Before disassembling the pump mechanism, move all input buffer bottles to below the level of the pump pistons to prevent siphoning.*

Note: *Always replace the piston seals on both piston heads of a pump module at the same time.*

Required spare parts and tools

Seal kit containing (see appendix D Accessories and Consumables for code numbers):

- Piston seal kit containing two piston seals, two gaskets and two wipers.
- M6 wrench (included in ÄKTAfplc tool kit).
- 2.5 mm Allen key (included in ÄKTAfplc tool kit).
- U-wrench NV 5.5 (included in ÄKTAfplc tool kit).

Note: *After new sealings have been installed, check the pump for leakage. See section 4.6 Testing leakage.*

4 Maintenance
4.7 Replacing the piston seal

Replacement instruction

CAUTION! Read the following instructions carefully. Avoid fitting the individual parts of the pump cylinder assembly incorrectly. Ensure that the orientation of each part is correct before continuing with the next instruction.

Setup Pulsecomp.
(on) on off

Run 1.00 ml/min

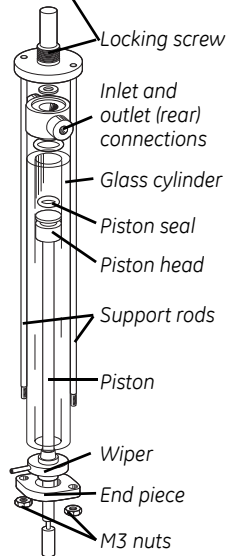
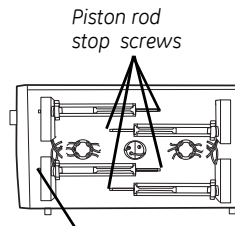
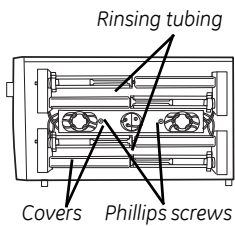

- 1 Use operating menu **Setup Pulsecomp.** to check that pulse compensation is off, see Section B.2.6. If not, select off. Otherwise, adjustment is not possible.
- 2 Start the pump and run until the piston head reaches the middle of its cylinder. Stop the pump by setting it to **END** work mode.
- 3 Switch OFF the pump at the mains power switch on the front panel.
- 4 Remove the protective perspex cover by unscrewing the fixing screws.
- 5 Remove the protective metal cover over the piston rod by gently pressing it together while pulling it off.
- 6 Remove the rinsing tubing. Also remove the tubing cover by undoing the two Phillips screws.
- 7 Disengage the piston rod from the driving arm by loosening the stop screw with the 2.5 mm Allen key.
- 8 Unscrew the locking screw for the pump cylinder assembly in a clock-wise direction and remove it. Disconnect the inlet and outlet tubings from the pump cylinder assembly.
- 9 Unscrew the M3 nuts from the support rods. Carefully remove the glass cylinder together with the end piece and gently pull out the piston.
- 10 Remove the piston seal using a needle. Be careful not to damage the piston head during this operation. Fit the new seal by hand.
- 11 The wiper is removed by pressing it out from the rod. Press a new wiper onto the rod. The hole on the wiper should point towards the pump head.

CAUTION! Do not push the piston at an angle to the cylinder and do not twist the piston.

- 12 Wet the piston head with distilled water and push it into the glass cylinder.
- 13 Change the end piece gasket located between the end piece and the glass cylinder. Use a spatula to remove the worn gasket.
- 14 Place the flat edge of the support rod assembly on a flat surface.
- 15 Mount the end piece on the support rod assembly so the tubing connectors are parallel to the flat edge.

- 16 Mount the glass cylinder with the piston and the wiper onto the end piece. Check that the rinsing tubing connector points upwards.
- 17 Make sure that both the end piece gasket and the wiper are in position. Insert the two support rods into the holes in the end piece. When the glass cylinder is properly seated, tighten the two M3 nuts gently.

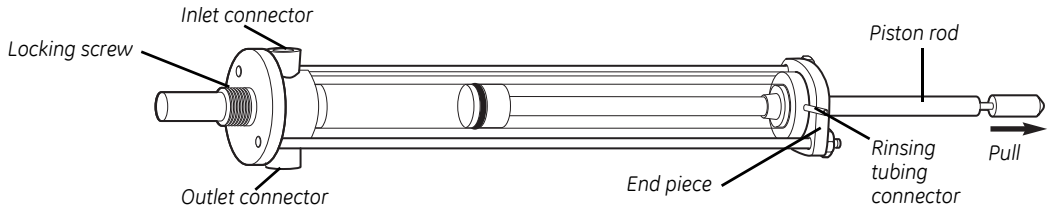

- 18 Refit the pump cylinder assembly. Check that the end piece rinsing tubing connector points towards you. Connect the inlet and outlet tubings to the pump cylinder assembly. Check the assembly alignment and the connections carefully to eliminate the risk of glass cylinders bursting when pressure is applied.
- 19 Tighten the locking screw for the pump cylinder assembly and pull the piston rod to the end piece.



WARNING! Hands and fingers risk being squeezed between the piston driving arm and the pump housing when running the pump without the protective covers fitted.

- 20 Switch on the pump with the mains power switch on the front panel. After the selftest, run the pump at a low flow rate so that the piston rod slips into the hole in the driving arm. Continue to run the pump until the 6-port pump valve switches. Just as the valve switches, stop the pump.
- 21 Engage the piston rod in the driving arm by tightening the stop screw with the Allen key.
- 22 Fill the rinsing system with 20% ethanol and replace the rinsing tubing.
- 23 Replace the tubing cover, the protective cover over the piston rod and the perspex cover. Make sure that no capillary is stuck between covers and the pump housing.
- 24 Run in the new sealings as described in section 2.8 Running-in the new pump.

4.8 Replacing a damaged piston

- 1 Typical symptoms of a damaged piston are observed as excessive piston seal wear, unstable pressure, a reduction in the flow or, in some cases, noise as the piston moves. The piston should be removed, examined for damage or salt precipitation and then replaced with a new piston if necessary.
- 2 If a damaged piston has been in operation, the piston seal will be destroyed and should also be replaced. To replace the piston and the seal, follow the instructions in section 4.7 Replacing the piston seal.
- 3 In addition to the spare parts listed in section 4.4, a **pump head complete** and possibly, if scratches are found inside the glass cylinder, a **glass cylinder** are also required (see appendix D Accessories and Consumables for code numbers).

4.9 Cleaning the 6-port pump valve

- 1 Faulty operation of the 6-way pump valve is usually indicated by no flow and that the pressure sensor gives no indication that the back pressure has increased. The probable cause is that one or more channels are blocked.
- 2 Identify the relevant pump cylinder assembly by observing which pump head is not delivering flow.



WARNING! Incorrectly fitted tubing may loosen, causing a jet of liquid to spray out. This is especially dangerous if hazardous chemicals are being used. Connect the tubing by first inserting the tubing fully, then tightening the connector fingertight. Finally tighten the internal connectors a further 1/4 turn using the key supplied.

CAUTION! Change the solvent to distilled water and flush out all salt before flushing the 6-port pump valve.

First, try to clean the inlet channel in-place by disconnecting the inlet tubing and the tubing from the corresponding pump cylinder assembly. Clean the channels in the valve by flushing nitrogen in reverse flow direction through the valve. Observe the capillary markings when reconnecting the tubing.

If this does not correct the problem, contact GE Healthcare for service.

5 Trouble-shooting

5.1 General

When contacting GE Healthcare for support, state the version number of the module. This is shown for 2 seconds during start-up. The version and model can also be checked by using the **Check Service Mode** operating menu.

We recommend you make a pressure recording since much information can be gained from the pressure trace. See section 5.5 Checking the pump pressure, for more information.



WARNING! The module must not be opened by the user. It contains high voltage circuits that can give a lethal electric shock.

5.2 Recycling



This symbol indicates that the waste of electrical and electronic equipment must not be disposed as unsorted municipal waste and must be collected separately. Please contact an authorized representative of the manufacturer for information concerning the decommissioning of equipment.

Always follow local rules and regulations for the disposal of waste materials and substances.

5.3 Faults and actions

If the suggested actions do not correct the fault, contact GE Healthcare.

Fault	Action
Large spillage over/into system/module	1 Unplug the mains inlet cable.
	2 Clean and dry the system/module with a dry cloth or paper. If necessary, tilt the system/module backwards to drain.
	3 Contact GE Healthcare local service for advice.
No text on the front display	1 Check that the mains cable is connected and the power switch is in ON-position I.
	2 Check the mains power supply.
	3 Check the mains inlet fuse.

Fault	Action
Erratic flow, noisy baseline signal, irregular pressure trace	
Air bubbles passing through or trapped in the pump	<ol style="list-style-type: none"> 1 Check that there is sufficient eluent present in the reservoirs. 2 Check all connections for leakage.
6-port pump valve not functioning correctly	<ol style="list-style-type: none"> 1 Follow the instructions in section 4.9 Cleaning the 6-port pump valve. 2 Clean the valve in-place. If improvement is not seen, contact GE Healthcare for service.
Piston seal leaking	<ol style="list-style-type: none"> 1 Replace the piston seal according to the instructions in section 4.7 Replacing the piston seal.
Blockage or partial blockage	<ol style="list-style-type: none"> 1 Flush through to clear blockage. 2 If necessary, replace tubing. 3 Check inlet tubing filter. It can become clogged if unfiltered buffers or samples are applied. <p>See instructions for flushing through at the end of the run in section 3.8 Ending the run and storage.</p>
Liquid leaking from the assembly or worn.	
Wiper and/or end piece gasket incorrectly fitted pump cylinder	<ol style="list-style-type: none"> 1 Replace or re-install the faulty part(s).
Low eluent flow and noise as the pistons move	<ol style="list-style-type: none"> 1 Disassemble the pump cylinder assembly and examine the piston seal and glass cylinder walls according to section 4.7 Replacing the piston seal. Replace if necessary. 2 If the glass cylinder walls are scratched, check the piston seal. Ensure that the piston rinsing system is always used, especially when working with aqueous buffers with high salt concentrations. 3 Check the piston for damage. If damaged, replace the piston according to section 4.8 Replacing a damaged piston. 4 Never reinstall used or old parts that may be worn.
Leaking connection and/or crystallized material around a connector	<ol style="list-style-type: none"> 1 Unscrew the tubing connector and check if it is worn or incorrectly fitted. If so, replace the connector. 2 Tighten the connector properly.
Error in external chart recorder	<ol style="list-style-type: none"> 1 Check the chart recorder according to its manual.

5.4 Error messages

If the suggested actions do not correct the fault, contact GE Healthcare.

**1 ERROR in software
notify instr support**

- 1 Reboot system.
- 2 If error remains, notify instrument support.

**33 ERROR in software
notify instr support**

**34 ERROR in software
notify instr support**

**35 ERROR in software
notify instr support**

**70 WARNING no mixer
Check connection**

- 1 Switch off the module.
- 2 Check the UniNet-2 connections to the mixer.

**71 Error in mixer
Check mixer**

- 3 Check the mixer.
- 4 Switch on the module.

**72 Error in UniNet2
Check units**

- 1 Switch off the module.
- 2 Check all UniNet-2 connections.

**73 WARNING UniNet2
Check connection**

- 3 Switch on the module.

**75 Error in valve A
Cont./Call service**

- 1 Switch off the module.
- 2 Switch on the module.

**76 Error in valve B
Cont./Call service**

- 3 If still persistent, call service.

**80 WARNING
Pump overpressure**

- 1 Check high pressure limit setting.
- 2 Check the column (may be blocked).

**81 WARNING
Pump underpressure**

- 3 Check the flowpath for blockage.

**82 WARNING pump
overheated check fan**

- 1 Check low pressure limit setting
- 2 Check the column (may be leaking).
- 3 Check the flowpath for leakage.
- 4 Check for air in the pump.

5 Trouble-shooting

5.4 Error messages

80 WARNING Pump overpressure	1 Switch off the module and let it cool. 2 Clean or clear the air inlets.
81 WARNING Pump underpressure	3 Switch on the module and check that the fan is running.
83 ERROR endsensors pump A call service	1 Call service.
84 ERROR endsensors pump B call service	
85 Failed to set offset	1 Reboot system. 2 If error remains, call service.
86 ERROR in EEPROM Recalib. all values	1 Call service for recalibration.
88 Not allowed current mode.	1 Select other instruction, or change mode (End, Run or Pause).
3300 Error software notify instr support	1 Reboot system. 2 If error remains, notify instrument support.
3400 Error software notify instr support	
3401 Error software notify instr support	
3410 Error software notify instr support	
3411 Error software notify instr support	
3510 Error software notify instr support	
3621 Error software notify instr support	
3622 Error software notify instr support	
3624 Error software notify instr support	

3600 Low lim>hi-lim	1 Low pressure limit can not be set higher than high pressure limit. Reset limit.
3605 Low lim>hi-lim Hysteresis	1 Low pressure limit for warning can not be set higher than high pressure limit for warning. Overlapping ranges due to hysteresis are not allowed. Reset limit.
3610 Disconpressure then set analog V.	1 Release pressure in system before setting analogue output voltage.
3620 Error hardware notify instr suppor	1 Call instrument support.
3636 Value must be greater than 0	1 Full scale pressure must be greater than zero. Reset value.
ERROR key (OK)	1 The key was pressed during self-test, or is faulty.
ERROR key (Esc)	2 Switch off the module.
ERROR key (OK+Esc)	3 Switch on the module.
ERROR number 100	1 Switch off the module.
ERROR number 109-113	2 Check all connections.
ERROR number 120-121	3 Switch on the module.
ERROR number 106-108	1 Switch off the module.
ERROR number 118	2 Check all UniNet 1 and UniNet 2 connections.
	3 Switch on the module.

5.5 *Checking the pump pressure*

To check the pump function, make a recording of the pressure on a chart recorder, or check the pressure in UNICORN. This pressure recording is more sensitive than the reading on the display. By observing the piston running indicator in Check menu (see section B.1.1) together with the pressure trace, the pump cylinder assembly which is functioning abnormally can be identified.

There can be several causes of an abnormal pressure recording, for example:

- partially blocked solvent filters
- leaking connections
- piston seal leakage
- 6-port pump valve malfunction
- piston and glass cylinder damaged
- flow restrictor blocked
- column blocked
- mixer blocked
- sample injection valve blocked

Appendix A Description

A.1 Module

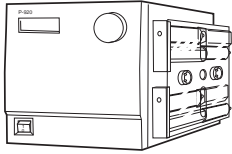

Pump P-920 is a high performance laboratory pump for use in liquid chromatography and other applications where constant liquid flow is required.

An eluent in an external vessel is drawn into the 6-port pump valve by the action of the pump cylinder assemblies. Twin reciprocating piston heads work in unison to deliver a smooth, low-pulsation flow from the pump pressure sensor housing.

The module contains no internal user-replaceable items.

A.2 Rear panel

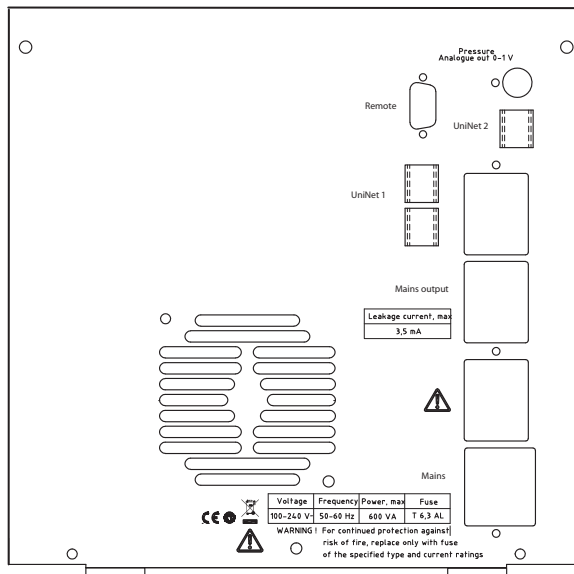

Connector/switch

Function

Pressure analogue out 0 to 1 V	Pressure signal to chart recorder
UniNet-2	Connection to Mixer M-925 and UniNet 2 network
UniNet-1	Connection to UniNet-1 network

A Description
A.3 Fluid delivery

Connector/switch	Function
Mains inlet with fuse	Supply voltage, grounded
Mains outlets	Supply voltage to UPC-900, Frac-920 and external units
0/1	Module on/off switch (on front panel)
Remote	Input/output for digital signals

Auxiliary equipment with digital signal interface can be connected to the 9-pole D-SUB female REMOTE connector (5 V TTL signals only).

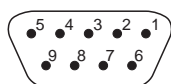

Pin	Signal	Function
1-4	Digital input 1-4	Active status = low or closed terminal to pin 5
5	0 V	Signal ground
6-9	Digital output 1-4	Active status = +5 V in reference to pin 5

When used in combination with UNICORN and the ÄKTAfplc strategy, 4 digital inputs and 4 digital outputs can be handled via the REMOTE connector. Pins 1-4 are used as inputs, and pins 6-9 as outputs. All input/output signals are 5 V TTL signals with ground reference to pin 5.

A.3 Fluid delivery

Pumping action is provided by a stepper motor, through a gear box and a ball screw, to two alternating pistons mounted on the right-hand side of the pump module.

The driving mechanism is located behind the side panel. The pistons reciprocate in two high precision glass cylinders. The pistons are driven so that one piston draws in solvent while the other expel solvent.

The change of piston direction is controlled by opto-electronic switches at the end positions. These switches also control the 6-port pump valve movement.

Each piston consists of three parts:

- head
- sealing
- connecting rod

The pump cylinder assembly is resistant to corrosive fluids and is easy to disassemble when servicing.

A.4 6-port pump valve

The 6-port pump valve is a motorized rotary valve driven by a DC motor through a gear box. The function of the valve is to control the solvent flow to and from the cylinder assemblies. The valve has six tubing connections.

The 6-port pump valve operates automatically when the pistons reach their end positions. The end positions are detected by optoelectronic switches. The valve is also operated when manual change of direction is ordered via the front dial.

In stand-alone applications, all connections except **IN** and **OUT** are fitted at the factory. When used in ÄKTAfplc chromatography systems, the **IN** and **OUT** connections are also connected at the factory.

A.5 Pressure monitoring

The pressure generated by the pump is continuously monitored by a pressure transducer housed in an outlet manifold block. The pressure transducer generates a signal which is proportional to pump pressure. This signal is read by UNICORN via the UniNet-1 connection, and is displayed on the front panel display. It is also fed to the rear panel connector **Pressure analogue out 0-1 V**, where 0.1 V corresponds to 1 MPa.

The pressure transducer has two main functions:

- to continuously measure the operating pressure
- to sense excessive pressure that could damage the columns

If the pressure builds up to the set limit, the pump automatically shuts down and an alarm is given.

A.6 Protective covers



WARNING! All protective covers over internal capillaries, piston rods and glass cylinders must be in place when running the pump.

Pump P-920 is equipped with covers to protect both the user and the pump from accidental damage.

A perspex cover is fitted over the fluid delivery side of the pump. The perspex cover is fixed with screws.

Metal covers are located over the moving part of the piston rods outside the glass cylinders. These covers are held in position by spring action.

A Description

A.7 Using an external chart recorder

A.7 Using an external chart recorder

The facility for recording the actual pressure at the pump outlet can be used for recording the pressure during an overnight run and for checking the pump function for any abnormality.

The external chart recorder output for pressure is 0 to 1 V, where 0.1 V corresponds to 1 MPa.

Appendix B Menus

B.1 Check menu

Select main operating menu **Check** and press **OK** to access the check sub menus.

CheckPistonStatus

A Left compressing
B Rightcompressing

B.1.1 Checking piston status

- 1 Select operating menu **Check Piston Status** and press **OK**.
- 2 The display shows if Left and Right cylinder assemblies are compressing for both pump modules A and B. If the pump is stopped, **stopped** is shown instead.

CheckPistonStrokes
A 123456789,B2398

B.1.2 Checking the number of piston strokes

- 1 Select operating menu **Check Piston Strokes** and press **OK**.
- 2 The display shows the accumulated number of piston strokes for the upper and lower pump cylinder assemblies.

CheckMixerrun time
15 Hous

B.1.3 Checking mixer run time

- 1 Select operating menu **Check Mixer run time** and press **OK**.
- 2 The display shows the accumulated run time for the mixer.

B.1.4 Checking service mode

Service information relevant to the module can be checked. Information may not be available in all menus.

CheckServiceMode

TelephoneService:

ContractNumber:

SerialNumber:

PumpP-920

Date of Maintenance:

BuzzerTest

- 1 Select operating menu **Check Service Mode** and press **OK**.
- 2 The service telephone number¹ is displayed. Press **OK**.
- 3 The service contract number¹ is displayed. Press **OK**.
- 4 The module serial number is displayed. Press **OK**.
- 5 The module name and software version are displayed. Press **OK**.
- 6 The date of the last service is displayed. Press **OK**.
- 7 A test of the module buzzer is performed. Press **OK**.

¹ Not always pre-programmed. Depends on customer-specific contract.

B.2 Setup menu

Select main operating menu Setup and press OK to access the setup sub menus.

B.2.1 Set pressure limit

Sets high and low pressure limits. When the limit is reached, the pump is set in **Pause** mode, a buzzer sounds and an error message **Overpressure** (for ascending pressure) or **Underpressure** (for descending pressure) is shown. This message has to be confirmed by pressing **OK**.

Setup Hi Press Limit
(5.00MPa) 4.50

- 1 Select sub menu **Setup Hi Press Limit**, press **OK**.
- 2 Set the value, press **OK**.
- 3 Repeat steps 1 and 2 for **Setup Lo Press Limit**.

Setup Lo Press Limit
(0.00MPa) 1.00

Note: *Low pressure limit cannot be set above High pressure limit and High pressure limit cannot be set below Low pressure limit. The low pressure limit check is delayed at start-up to allow for system pressure build-up.*

B.2.2 Set wash pressure limit

Sets wash pressure high limit. When the limit is reached, the pump is set in **Pause** mode, a buzzer sounds and an error message **Wash overpressure** is shown. This message has to be confirmed by pressing **OK**.

Setup Wash Press Lim
(5.00MPa) 4.50

- 1 Select sub menu **Setup Wash Press Lim**, press **OK**.
- 2 Set the value, press **OK**.

B.2.3 Set pressure unit

Sets the pressure unit used in the display.

Setup Pressure Unit
(bar) MPa bar psi

- 1 Select sub menu **Setup Pressure Unit**, press **OK**.
- 2 Select either MPa, bar or psi, press **OK**.

B.2.4 Set gradient base

Sets the base for the gradient to either time or volume.

Setup Gradient Base
(time) time volume

- 1 Select sub menu **Setup Gradient Base**, press **OK**.
- 2 Select either time or volume, press **OK**.

B.2.5 Set mixer operation

Sets the condition of the mixer connected to the pump.

Setup Mixer
(auto) on off auto

- 1 Select sub menu **Setup Mixer**, press **OK**.
- 2 Select either on, off or auto, press **OK**. “**auto**” means the mixer is running when the pump is in **Run, Pause** or **Hold** mode

B.2.6 Set pulse compensation mode

Sets the condition for pulse compensation.

Setup Pulsecomp.
(on) on off

- 1 Select sub menu **Setup Pulsecomp.**, press **OK**.
- 2 Select either on or off, press **OK**.

B.2.7 Set pressure offset

Allows pressure offset calibration.

Setup Press Offset

- 1 Select sub menu **Setup Press Offset**, press **OK**.

Note! Zero pressure

- 2 A warning message is shown that the pressure must be zero in the pressure transducer to perform the calibration.

Calib Press Offset

- 3 Press **OK** to acknowledge or **Esc** to cancel. When acknowledged, the display returns to **Setup Press Offset**.

Calib Press Offset

- 4 Press **OK** to perform the calibration.

B.2.8 Setup language

Sets the language used in the display.

Setup language

- 1 Select sub menu **Setup Language** and press **OK**.
- 2 Select the desired language.

GB = English

D = German

F = French

E = Spanish

I = Italian

B.2.9 Setup unit number

The unit number is the identification the pump has on the UniNet-1 communication link. It should correspond to the number set in UNICORN for the pump. The number should be set to 0 if one pump is used. If more than one pump is used, they must all have different identification numbers. Factory default setting=0.

Setup Unit Number
(0)

- 1 Select sub menu **Setup Unit Number**, press **OK**.
- 2 Select unit number (0–25), press **OK**.

B.2.10 Setup display angle

Sets the display angle to compensate for different viewing heights.

Set Display Angle
(->|) ->| ->| ->|

- 1 Select main menu **Setup**, press **OK**.
- 2 Select sub menu **Set Display Angle**, press **OK**.
- 3 Select display angle (->| Up, ->| Mid or ->| Down), press **OK**.

B.3 Alarm timer

You can set the alarm function to either a fixed alarm time or use a count-down timer. The pump can be started or stopped automatically, or an alarm can sound, at the set time. It is not possible to set both an alarm time and the count-down timer. Current values are shown in parentheses.

Alarm/Timer 12:30:52

Alarm/Timer Action

Set Alarm 12:32:21

Set Timer

Alarm/Timer 12:30:52

12:41:29 12:41:49

- 1 Select main menu **Alarm/Timer**, press **OK**.
- 2 Set the action to take place. Press **OK** to select action. **Buzzer** will generate an audible alarm for 15 s with a message. **Run** will start the pump at the set flow rate. **End** will stop the pump. Each generates one beep and a message.
- 3 Use the sub menu **Set Alarm** if you want to set an alarm at a fixed time. Press **OK** to enter the time in the form **HH.MM.SS**. Press the **OK** button after entering each time unit.
- 4 If you want to set a count-down time, turn the dial to select sub menu **Set Timer**. Press **OK** to enter the count-down value in the form **HH.MM.SS**. Press the **OK** button after entering each time unit.
- 5 Press **ESC** button to return to the **Alarm/Timer menu**, which now shows the set alarm time or count-down time as **BuzzerHH:MM:SS**.
- 6 When the alarm time is due or the count-down timer reaches 00:00:00, an alert display is shown and the module beeps, until the OK button is pressed. A second alert display is shown, until the OK button is pressed.

Set Clock

The alarm timer is based on the internal module clock, which can be set in the **Set Clock** menu located after the **Alarm/Timer** menu. The clock will be reset when power is turned OFF.

Alarm/Timer off?

A set alarm/timer function can be reset by pressing **OK** in the menu **Alarm/Timer off?**

B.4 Service displays

Enter Access Code!

The module has service displays for use by authorized service personnel. If the service display **Enter Access Code!** is accidentally selected, press the **ESC**-button to return to the normal operating menus.

B.5 Menu and text overview

Turn **Dial** to select menus on same level. Press **OK** to acknowledge selection. Press **Esc** to move up one menu level. Press **Esc** again to move up further.

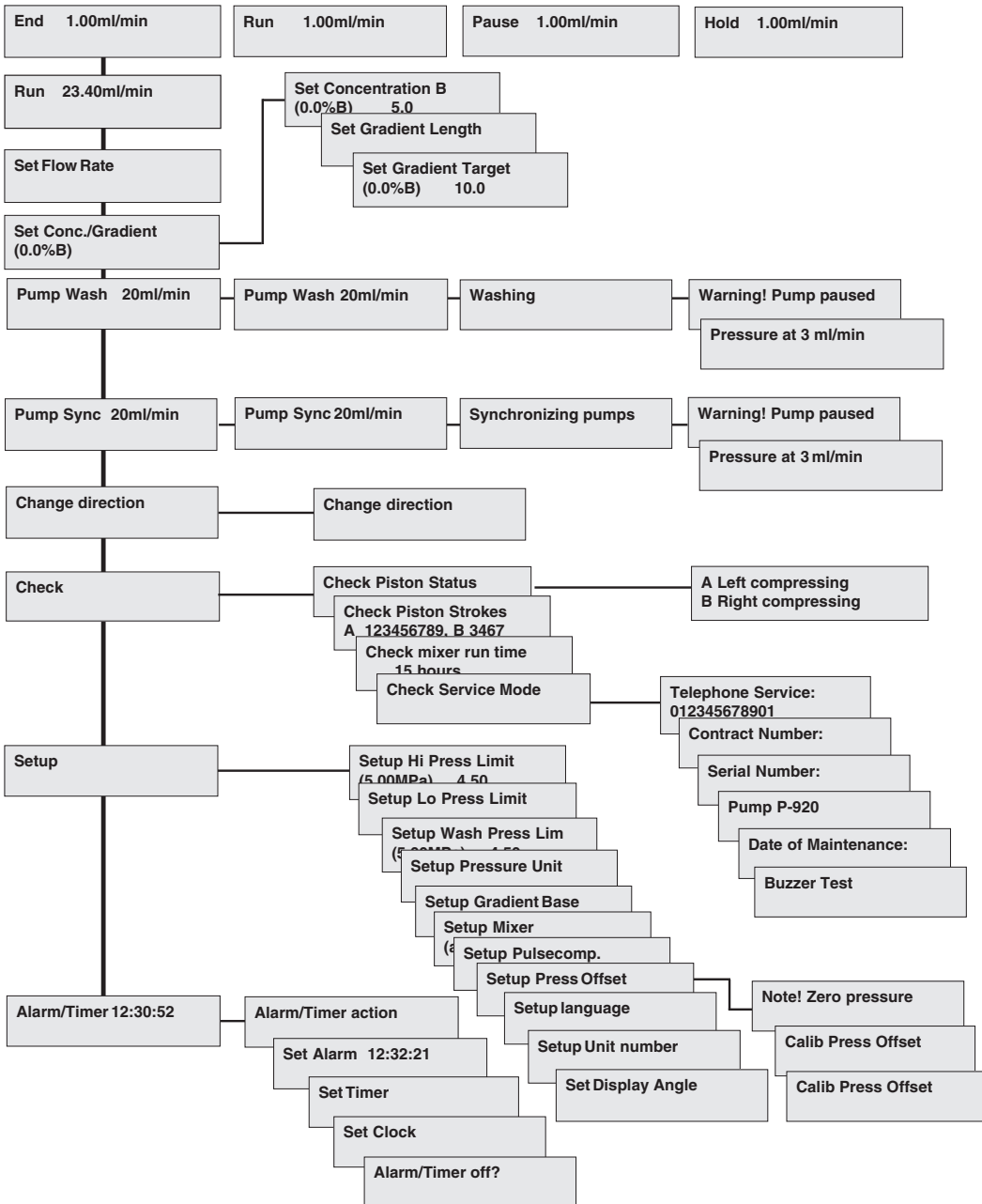

Appendix C Technical Specifications

C.1 Operating data

Flow rate range

isocratic mode 0.01 to 20 ml/min in steps of 10 μ l/min

gradient mode 0.1 to 20 ml/min in steps of 1 μ l/min

Pressure range 0 to 5 MPa (50 bar, 725 psi)

Pressure pulsation Max. 6% (dP/P) during pump stroke

pH stability range 1 to 13, (1 to 14 <1 day exposure)

Viscosity Max 5 cP for complete flow rate range. At reduced flow rate (5 ml/min); 10 cP

Flow rate reproducibility

flow rate 0.5 to 10 ml/min rsd < 0.2%

Gradient composition

accuracy between turnings \pm 2% at 0.5 to 5 ml/min and <5 MPa

accuracy during turnings \pm 2% at 0.5 to 5 ml/min and 0.5 to 2.0 MPa

reproducibility rsd <0.5% at 0.5 to 20 ml/min and <5 MPa

Leakage <0.5 ml/min (pump module A and B each)

Pressure sensor

range 0 to 7 MPa

offset error Max. \pm 0.05 MPa

scale error Max. \pm 2%

C.2 *Physical data*

Delay volumes

per pump cylinder assembly	10 ml
Inlet tubing	Tubing connector for 1/8" o.d. tubing
Outlet tubing	Fingertight connector, 1/16" o.d.
Fuse specification	T 6.3 AL, 250V
Control	Stand-alone or from a PC running UNICORN version 3.0 or higher, via UniNet-1 cable connection.
Degree of protection housing	IP 20
Wetted materials	
piston head	PEEK
piston rod	Titanium
glass cylinder	Borosilicate glass
pump seal	Simriz
6-port valve	PEEK, titanium and ruby/sapphire.
Chemical resistance	The wetted parts are resistant to organic solvents and salt buffers commonly used in chromatography of biomolecules.
Power requirement	100 to 240 V AC, 50 to 60 Hz
Max. Power consumption	600 VA including accessories
Digital input 5 V	TTL low or contact closure (see section A.2 for pin connections)
Digital output	TTL, open collectors
Recorder output	0 to 1 V full scale (0.1 V corresponds to 1 MPa)
Functions	Languages available; English, German, Spanish, French, Italian
Display	2 rows with 20 characters each
Environment	+4°C to +40°C 20% to 95% relative humidity 84 to 106 kPa (840 to 1060 mbar)
Dimensions, H x W x D	150 x 260 x 370 mm
Weight	18 kg

C.3 *Regulatory Requirements*

Safety standards

This product meets the requirement of the Low Voltage Directive (LVD) 73/23/EEC through the following harmonized standards:

- EN 61010-1
- IEC 61010-1
- CAN/CSA-C22.2 No. 61010-1
- UL61010-1





EMC standards

This device meets the requirements of the EMC Directive 89/336/EEC through the following harmonized standards:

- EN 61326 (emission and immunity)
- EN 55011, GR 2, Class A (emission)
- This device complies with part 15 of the FCC rules (emission). Operation is subject to the following two conditions:
 - 1 This device may not cause harmful interference.
 - 2 This device must accept any interference received, including interference that may cause undesired operation.

C Technical Specifications
C.3 Regulatory Requirements

Appendix D Accessories and Consumables

	Item	Quant./pack	A/C ¹	Code no.
	Sealing kit, containing two sealings, two gaskets and two wipers	1	C	18-1032-16
	Pump head complete	1	A	18-1032-15
	Glass cylinder	1	A	18-1512-01
	Internal tubing kit P-920	1	C	18-1128-70
	Rinsing tubing, 1.1 mm i.d., 3.1 mm o.d.	2 m	A	18-1032-11
	Union 1/16" female/M6 male, PEEK	6	A	18-1112-57
	Fingertight connector 1/16", for PEEK tubing o.d. 1/16"	10	A	18-1112-55
	Union, 1/16" male/1/16" male, for 1/16" o.d. tubing, PEEK	10	A	18-1120-92
	Stop plug, 5/16", PEEK	5	A	18-1112-50
	Stop plug, 1/16", PEEK	5	A	18-1112-52
	Tubing cutter	1	A	18-1112-46
	U-wrench, M6	1	A	19-7481-01
	U-wrench, 1/4"	1	A	18-1112-45
	Allen key, 2.5 mm	1	A	19-4442-01
	Signal cable, 6 pin mini-DIN – open	1	A	18-1110-64
	Chart Recorder REC 111, 1 channel	1	A	18-1132-32
	Chart Recorder REC 112, 2 channel	1	A	18-1132-33

¹ A = accessories, C = consumables

D Accessories and Consumables

Appendix E Short Instructions

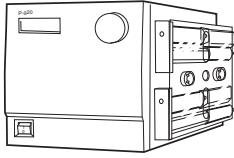

The following short instructions are intended as a guide to users who are fully familiar with the safety precautions and operating instructions described in this manual. These short instructions assume that the module is installed according to the installation instructions.

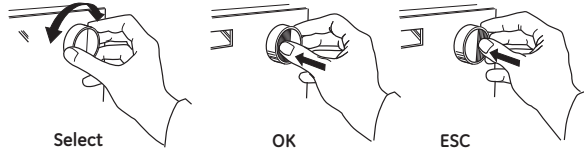

- 1 Switch on the module with the mains switch on the rear panel.
- 2 A self-test is performed.

Selftest
- 3 The version number is shown for two seconds.

Pump P-920
- 4 The **main operating menu** is shown.

End 0.00 ml/min
- 5 Set the flow rate.

Set Flow Rate
(0.00ml/min) 2.5
- 6 Start the pump by setting it in **RUN** mode.

End 2.50ml/min
Run
- 7 The **main operating menu** is shown.

Run 2.50 ml/min
2.0 MPa 0.0%B
- 8 Set concentration and gradient.

Set Conc./Gradient
(0.0%B) 10.0
- 9 Start a gradient by setting the **Gradient Length** and **Gradient Target**.

Set Gradient Length

Set Gradient Target
(0.0%B) 10.0
- 10 Stop the pump by setting it in **END** mode.

End 2.50ml/min
Run

For contact information for your local office,
please visit:
www.gelifesciences.com/contact

GE Healthcare Bio-Sciences AB
Björkgatan 30
751 84 Uppsala
Sweden

www.gelifesciences.com

GE, imagination at work and GE monogram are trademarks of General Electric Company.

Drop Design, ÅKTA and ÅKTAFLC are trademarks of GE Healthcare companies.

UNICORN: Any use of this software is subject to GE Healthcare Standard Software End-User License Agreement for Life Sciences Software Products.

All third party trademarks are the property of their respective owners.

© 2004-2008 General Electric Company—All rights reserved.
First published Jan. 2004.

All goods and services are sold subject to the terms and conditions of sale of the company within GE Healthcare which supplies them. A copy of these terms and conditions is available on request. Contact your local GE Healthcare representative for the most current information.

GE Healthcare UK Ltd
Amersham Place,
Little Chalfont,
Buckinghamshire, HP7 9NA,
UK

GE Healthcare Bio-Sciences Corp
800 Centennial Avenue,
P.O. Box 1327, Piscataway,
NJ 08855-1327,
USA

GE Healthcare Europe GmbH
Munzinger Strasse 5,
D-79111 Freiburg,
Germany

GE Healthcare Bio-Sciences KK
Sanken Bldg. 3-25-1,
Hyakunincho, Shinjuku-ku,
Tokyo 169-0073,
Japan



imagination at work